



A STUDY ON THE EVALUATION METHOD OF MBR MEMBRANE REPLACEMENT USING PERMEABILITY ATTENUATION

^{1,*} Li, D., ¹ Zhang, X. M., ^{1,2} Hao, J. Y., ¹ Ma, Q. H. and ³ Fu B.

¹Energy and Chemical Engineering Research Center, Xi'an Siyuan University, Xi'an 710038

²School of chemical engineering and technology, Xi'an Jiaotong University, Xi'an 710049

³Regenerative Water Plant, Xi'an Siyuan University, Xi'an 710038

Received 13th April 2022; Accepted 07th May 2022; Published online 16th June 2022

Abstract

All 3520 days' operational data of an A²/O-MBR RWTP in Xi'an Siyuan University have been indiscriminately used to study an evaluation method of MBR hollow fibre membrane replacement. Two dimensionality reductions are carried out to obtain the annual industrial permeability, VMD₂, from their daily values, as well as the annual trans-membrane pressure, TMP₂, from the daily values. In the operation conditions, as membranes aging, three phenomena can be observed simultaneously. The permeate volume declined annually about 0.78 m³ per day per 1000 m² membrane area per kPa TMP; The trans-membrane pressure increased annually about 0.66 kPa. The production capacity of the RWTP is annually decreased 47 m³ per day, decreased 2.41% from the original designed capacity. The frequency of cleaning events qualitatively increases. In a practical point of view, the membrane replacement interval is a technical and economic planned exercise, and affected by the MBR process design, the actual operating conditions, such as constant flux operation, different cleaning methods and procedures etc. Even though, data used in this paper have come out with limitation, but the methodology used still be meaningful.

Keywords: Membrane bio-reactor (MBR), Membrane replacement, Industrial permeability (VMD), Trans-membrane pressure (TMP), Permeability attenuation.

INTRODUCTION

Since the first industrial scale MBR was put into operation in 2006 in China, the capacity of MBR for waste water treatment has been reached 7.5×10^6 m³/d in the next 10 years (Xiao *et al.*, 2014). Many research articles published regarding the MBR application engineering design (Hou *et al.*, 2011; Yang *et al.*, 2011; Fan and Jiang, 2010; Zhang *et al.*, 2013), membrane fouling and cleaning prevention (Jiang *et al.*, 2013; Zhang *et al.*, 2020; Cote *et al.*, 2012), and cost analysis etc (Meng *et al.*, 2009; Verrecht *et al.*, 2010; Li *et al.*, 2022). But only few papers are related to the T_{life} or membrane replacement evaluation (Fenu *et al.*, 2012), such as the evaluation of T_{life} for RWTP in 2014 (Wang *et al.*, 2014), T_{life} assessment for municipal wastewater treatment in 2015 (Xu *et al.*, 2015), and T_{life} prediction of ultra-filtration membrane in water treatment plant in 2020 (Liu *et al.*, 2020). These three articles had used their own experience and data and evaluated several methods for T_{life} prediction. The non-negligible conclusion is that it is feasible to use the permeability decay curve to reflect the irreversible fouling of the membrane, so it is a good idea to predict the T_{life}. Even for those few articles revealed the T_{life} prediction published in the last decade, the follow up of those predictions has not been found. Therefore, the accuracy and details of those predictions cannot be credited. Since the equipment whole life cycle management and the pursuit of benefits are two most important reasons for T_{life} research, the membrane life prediction is not only a technical problem but also an economic problem. An A²/O-MBR (Anaerobic - Anoxic - Aerobic Membrane Bio-Reactor) RWTP has been built in 2011 and started to operation in Xi'an Siyuan University (Li *et al.*, 2017, 2019 & 2022; Zhou *et al.*, 2022;).

This aging RWTP has been still running without replacing any membrane, which offers new insights from an operational perspective. Several issues can in fact be disclosed only after such long term operations in sub-optimal conditions, such as the designed flow diagram effects, inter-relation between constant flux operation and membrane cleaning procedures, etc. This paper takes the near 10 years operation of membrane as an example, only focus on the permeability decline phenomena, from the rationality and practicability point of view to study MBR membrane replacement.

Xi'an Siyuan University A²/O-MBR RWTP

Since the MBR process design, such as regulated tank and buffer tanks, and the actual operating conditions, such as constant flux operation, different cleaning methods and procedures etc. have strongly affected the RWTP operation, therefore, all details are described first.

A²/O-MBR present process

Xi'an Siyuan University uses PVDF hollow fiber membrane for an A²/O-MBR membrane RWTP. The RWTP was built in September 2011, including the production capacity of 2000 m³/d (1#, 2#, and 3# membrane tanks, 1,800 m² for each tank), and operated in constant flux mode. In order to deal with the permeability decline of original MBR after over 9 years running and additional requirement of 680,000 m² new green land irrigation of the local government contracted, the University has installed the another 2000 m³/d (4#, 5#, and 6# membrane tanks) and operated in the March 2021. Now a total of 4000 m³ MBR with 10800 m² membrane area is in operation. Since each membrane tank has its own permeate pump, the new and old membrane is impossible to be operated by a same pump.

*Corresponding Author: Li, D.,

Energy and Chemical Engineering Research Center, Xi'an Siyuan University, Xi'an 710038.

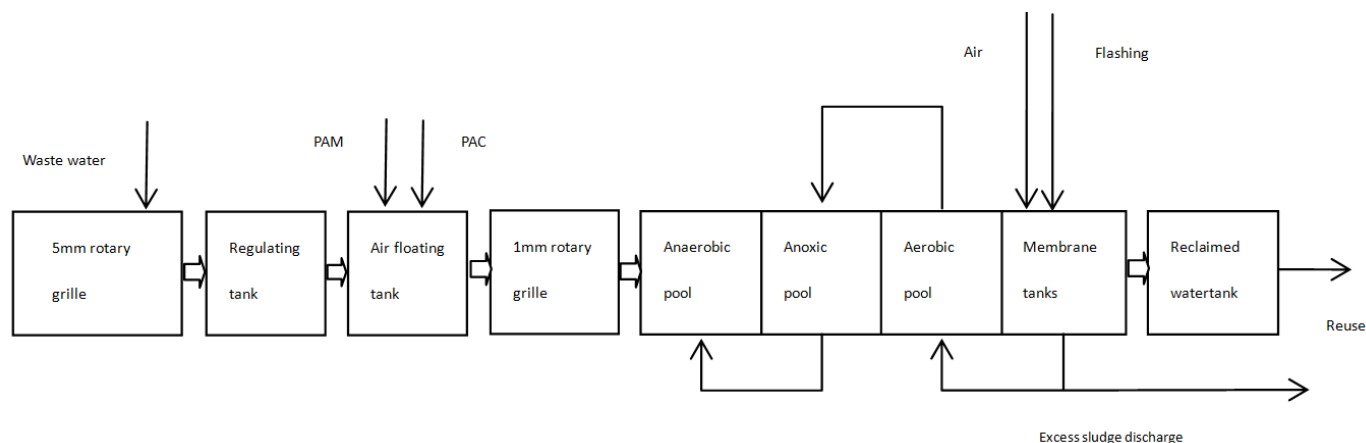

Figure 1. The current process of A²/O-MBR of Xi'an Siyuan University RWTP

The new and old membrane being operated by a same pump will lead to uneven flow distribution and rapid fouling of the new membranes. There are all kinds of data (water inlet flow, TMP, suction pump frequency, water yield turbidity, pH value, temperature, cumulative water yield, etc.) showing on the control panel. Those are recorded once per day in the daily report at 8:30 a.m. of morning shift. Figure 1 shows the current process flow of the A²/O-MBR reclaimed water plant.

Regulating tank

The role of the 1200 m³ regulating tank shown in the Figure 1 is to adjust the quality and quantity of campus' waste water. The daily influent profile of university campus is always changing because of the orderly schedule of work and rest, classes and dining time, and the teacher and student activities on weekdays or weekends, school opening or closing months. Therefore, dynamic influent profile of campus waste water is different to that of municipal waste water. It is necessary to regulate the fluctuating influent into the regulating tank for equalization and adjustment before the waste water enters the treatment body, so that both the quantity and quality are relatively stable, so as to provide a stable and optimized operating conditions for the subsequent water treatment system.

Reclaimed water buffer tank

Since the whole northwest region lacks water resources and the environment is fragile, all the reclaimed water out of RWTP needs to be reused. In order to reuse the reclaimed water, it is regularly tested against the national standard "The reuse of urban recycling water - water quality standard for scenic environment use (GB/T 18921-2002)". The design of the reclaimed water reuse system not only considers the Xi'an Siyuan University terrain, but also considers solving the residence time requirement of reclaimed water, and to deal with the very accidental excessive phosphorus and nitrogen concentration in the reclaimed water. The reclaimed water is first pressurized and flows into different buffer tanks, including one 3000 m³ ornamental lakes, five storage tanks of 890 m³, and three ornamental fountains of 600 m³, and then being reused in three ways: toilets flushing, road surface cleaning, and irrigation of green grass and trees. In case of phosphorus and nitrogen exceeding the standard occasionally, the cultivate aquatic plants in the ornamental lake can reduce phosphorus and nitrogen concentration too.

Time frame for the membrane operation data collecting

From 31st October 2011 to 31st October 2021, a total of 3,651 days of running data of 1[#], 2[#], and 3[#] membrane tanks, is selected for the membrane permeability study. Due to the epidemic of COVID-19 in 2020, the RWTP is closed from January 8 to May 19 for 131 days. The actual number of days in this study are 3520 days, 9.644 years.

History of optimization within the operation period

During 9.644 years RWTP operation, some equipment have been added, and some cleaning processes have been optimized. Those additional equipment and optimized processes are:

1. Increases the air float tanks. In November 2020, the RWTP added two air floating tanks between the regulating tank and 1mm rotary drum grille. Two kinds of flocculant, Polyacrylamide and Polymerized aluminum chloride, have been added to the air float tanks;
2. Optimizes the Maintainability Cleaning (EFM) process;
3. Optimizes the sequence of membrane's chemical offline cleaning (CIP);
4. Artificial Physical Maintenance cleans the hair.

Constant flux operation

There are two kinds of filtration mode: constant flux filtration mode and constant pressure filtration mode. Xi'an Siyuan University's RWTP operates at a constant flux mode with designed flux LMH=16.0. The constant flux operation is ensured by setting two important parameters: the production rate for each membrane tank, m³/h; and the trans-membrane pressure for each membrane tank, kPa. The designed production capacity (DPC) for each membrane tank is

$$\frac{16L}{1hour \times m^2} \times \frac{1800m^2}{1tan k} \times \frac{1m^3}{1000L} = 28.8m^3 / (tan k \times hour) \quad (1)$$

So the daily DPC for RWTP, 1[#], 2[#], and 3[#] membrane tanks, is 2000m³. The rule of setting production rate in membrane tank is based on the usage demand of the downstream and the proper balance between the influent quantity in the regulate tank and effluent quantity in the buffer tanks. The setting value is always controlled between 10-30 m³/h, about 35%-104% of the designed value. The rule of setting the TMP is based on the cumulative water production, or the cumulative operation time. The maximum TMP has never been set over 50 kPa. If the

actual TMP reached the setting value, the suction pump stops, and then the membrane tank is forced to perform the necessary cleaning.

Maintenance and cleaning of membrane

MBR was pumped intermittently pumped by a self-suction pump with a stop time ratio of 9 min / 1 min. During the MBR operation, the membrane trapped the solid suspension in the mixture, and a compressible filter cake was formed on the membrane surface. The filter cake itself can also act as a filter medium to enhance the filtration performance of the device. However, the filter cake layer also needs to be controlled to ensure that the TMP remains within a reasonable range during the filtration process. In order to effectively control the membrane pollution and cake layer, extend the service life of the membrane, four kinds of membrane cleaning have been carried out since the MBR starts running.

Membrane BW: Membrane BW was performed automatically by MBR from a self-suction pump. On BW, the membrane filtration process stops working, the TMP is reduced to 0. A penetrating liquid pump is used to draw water from the reverse wash tank and enter the inside and outside of the membrane filament to flush the pollutants accumulated from the surface of the membrane filament away from the surface. The water production time of 9 min and the backwash time of 1 minute. The membrane filtration rate is maintained by back washing. After a long run, a small deposition of contaminants on the membrane filament surface accumulates over time, which leads the membrane filtration resistance gradually increase.

Maintenance Cleaning (EFM): In order to effectively remove pollutants from the membrane surface, regular maintenance cleaning (EFM) of the membrane components is required. The MBR system needs a maintenance cleaning (EFM) of sodium hypochlorite about every week, which takes about 90 minutes. The MBR system needs a maintenance cleaning (EFM) of citric acid about every month, which takes about 5 minutes. During the EFM, the membrane group was always completely immersed in the mixture.

Chemical Offline Cleaning (CIP): Chemical offline cleaning (CIP) frequency is 3-6 months once, the process is to add the diluted cleaning chemical agent in the membrane tank, through the liquid pump cleaning agent through the membrane into a circulation loop, thus greatly improving the chemical cleaning effect. The cleaning process is 1.96wt% citric acid solution first for 8-10 hours, then 1wt% sodium hydroxide (NaOH) to pH 6-9. After that, 0.9wt% sodium hypochlorite (NaClO) for 8-10 hours, then 0.5wt% sodium sulfite (Na_2SO_3) to pH 6-9. The chemical offline cleaning (CIP) membrane group is completely immersed in the cleaning solution.

Physical cleaning: There are over 20,000 male and female students and faculty members in Xi'an Siyuan University. There is a lot long hair in the influent of campus' wastewater, which will twine on the membrane filament, and lead to reduce the water production of the membrane and even snap off the membrane filament. Before CIP cleaning on schedule, a physical cleaning is carried out by hand one filament after one filament. So, the physical cleaning is the most tedious and annoying cleaning procedure, but which can maximize the recovery of the TMP.

Permeability attenuation

All pieces of quantitative information are available regarding the robustness of hollow fibre membranes used in Xi'an Siyuan University's immersed MBR RWTP. The data includes the daily water inlet flow, TMP, suction pump frequency, turbidity, pH value, temperature, reclaimed water yield, etc. for over 10 years. Therefore, the relative contribution of permeability loss during the treated 7.554 million cubic meters of campus waste water, produced 4.961 million cubic meters of reclaimed water are available. The first hand experience provides us an unique position to analyze the permeability attenuation phenomena and answer some operational questions.

Industrial permeability

VMD has been defined as "industrial permeability", which is the cubic meter permeate volume per day per 1000 meter square membrane area per kPa TMP without temperature normalization. VMD is a fraction with daily permeate as the numerator and TMP as denominator. The VMD definition has three major advantages comparing with regular permeability, It is suitable for large industrial scale calculation; The membrane area in each MBR membrane tank is $1,800 \text{ m}^2$. Therefore, the VMD of each membrane tank is available by dividing the daily water yield by the TMP and then by 1.8; Two important quantities (daily water yield and TMP) of the whole operation period (9.644 years) can be obtained directly from the computer in the control room without additional calculation; and Permeability is a terminology related to permeate volume under unit time unit membrane area and unit TMP. Any additional prefix cannot change permeability's dimension. Contrary, flux is a terminology related to permeate volume under unit time unit membrane area. A prefix, such as "specific flux", changes the dimension of flux-being irrelevant with TMP into specific flux-being related with TMP. It is very confusion between flux and specific flux.

Valid industrial permeability

There are a few kinds of abnormalities in the 3520 daily VMD, such as both numerator and denominator were zero, one of numerator and denominator was zero or very small. Those abnormalities were caused by the objective reasons, such as instrument malfunction or fixed recording time, etc. After removing all the abnormal points one by one, the "valid industrial permeability" of each membrane tank is produced. The number of valid VMD for the three membrane tanks are listed in Table 1.

The first dimensionality reduction and statistical calculation

In authors' point of view that all valid VMD should be and must be indiscriminately used in the MBR permeability attenuation analysis. This is the foundation to guarantee for the quantity, rationality, and practicability of intelligent diagnosis and decision-making process, such as membrane replacement. Since there are over twenty five hundreds of valid VMD for each membrane tank, the first dimensionality reduction is conducted by artificially grouping 25 valid daily VMD into one group.

The VMD1 is the arithmetic mean within each group, and is calculated by:

$$VMD1 = \frac{\sum_{i=1}^{25} x_i}{25} \tag{2}$$

Where x_i is the i^{th} VMD, and there are 25 valid VMD in one group unit. There are three membrane tanks in Xi' an Siyuan University RWTP. The first dimensionality reduction results of other two tanks are listed in Table 1.

Table 1. VMD for each of the three membrane tanks

Item	1 [#]	2 [#]	3 [#]
VMD/day	3520	3520	3520
valid VMD/day	2474	2725	2652
Group/#	98	109	106
Time/year	9.644	9.644	9.644
Ratio/#/year	10.16	11.30	10.99

Now, taken 1[#] membrane tank as the example for illustration. The VMD1 vs time of 1[#] membrane tank is plotted in Figure 2.

From Figure 2, it is easy to observe the value of VMD1 is generally decrease with the running time. In the actual operating condition, VMD1 value is declining and its up-down distribution is scattering narrowly along with time. Obviously, two curves can be drawn in Figure 2: one up line places along the highest points, and another down line draws following the lowest points. These two lines divide the picture into two blank sections without any plotting points and one non-blank area located between two curves.

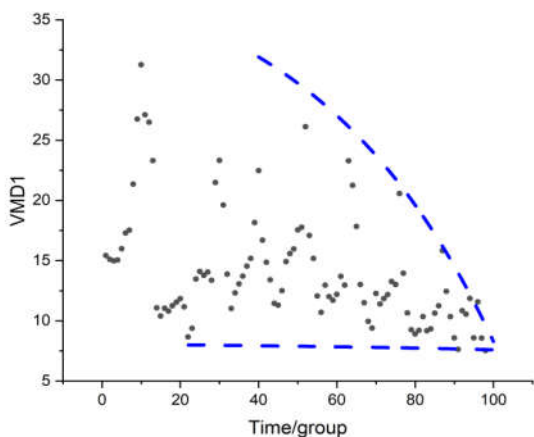

Figure 2. The VMD1vs time of 1[#] membrane tank

The point of VMD1 is not one daily VMD, but, instead, 25 daily VMD. Therefore, the points in VMD1 up curve is not the maximum flux after offline chemical cleaning, and the points in VMD1 down curve is not the specific flux at the highest operating pressure. The distance between these two lines can still be imagined as the efficiency of chemical cleaning. In the actual constant flux operating experience, it is never reaching the highest TMP. Based on the practical experience, other membrane cleaning procedures, such as membrane BW, maintenance cleaning, or chemical offline cleaning does participate in preventing TMP further building up before the highest TMP been reached. Even the two curves meet at some point very soon, the meeting point is not the theoretic Tlife. It is more reasonable to use membrane replacement instead of

using Tlife. First of all, the Tlife concept remains being debated by membrane manufactures, water treatment plant operators, academic researchers, and constitution experimenters. From an operation and maintenance point of view, this methodology study is less like the Tlife prediction but rather like a MBR membrane replacement evaluation. The degree of distributing dispersion can be evaluated by calculating the standard deviation, which is the measure of the dispersion of the data distribution, i. e., used to measure the extent that the data values deviate from the arithmetic mean. The smaller the standard deviation, the less these values deviate from the mean, and vice versa.

The standard deviation within each group was calculated by

$$stdevVMD1 = \sqrt{\frac{\sum_{i=1}^{25} (x_i - VMD1)^2}{24}} \tag{3}$$

The calculated results is plotted in Figure 3.

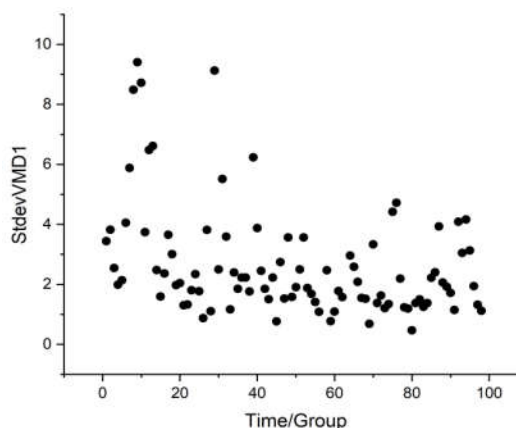

Figure 3. stdevVMD1 vs time of 1[#] membrane tank

From Figure 3, it is easy to observed that stdevVMD1 is higher at the beginning and the end but lower at the middle, just like gondola shape.

Trans-membrane pressure

Since VMD is a fraction with daily permeate volume as the numerator and TMP as the denominator, there must be three ways to decrease VMD. One is keep the TMP unchanged but the permeate volume decrease, which means to reduce the numerator. Another is keep permeate volume unchanged but the TMP increase, which means to rise denominator. The most significant way is to reduce the numerator and to rise denominator simultaneously. The data of TMP should be treated follow the same procedure, collecting every daily TMP, eliminating unusual ones, grouping 25 valid TMP as the first dimensionality reduction, calculated the arithmetic mean within each group TMP1 by:

$$TMP1 = \frac{\sum_{i=1}^{25} x_i}{25} \tag{4}$$

Where x_i is the i^{th} TMP, and there are 25 valid daily TMP in one group. The first dimensionality reduction results of all three tanks are listed in Table 2.

Table 2. TMP for each of the three membrane tanks

Item	1#	2#	3#
TMP/day	3520	3520	3520
valid TMP/day	2600	2849	2801
Group/#	104	114	112
Time/year	9.644	9.644	9.644
Ratio/#/year	10.78	11.82	11.61

Figure 4 is the TMP1 vs time of 1# membrane tank.

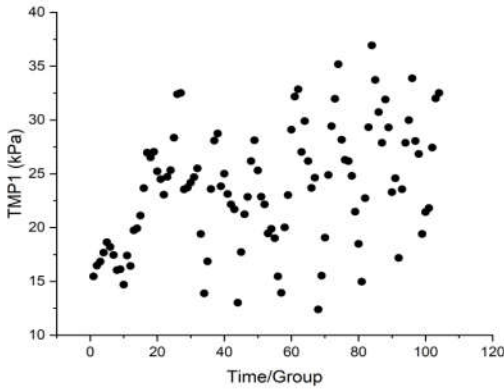

Figure 4. The TMP1 vs time of 1# membrane tank

From Figure 4, it is easy to observe the value of TMP1 is generally increase with the running time. In the actual operating condition, TMP1 value is increasing and its up-down distribution is scattering broadly along with time. Taking 1# membrane tank as an example, compare the TMP1 vs time in Figure 4 and the VMD1 vs time in Figure 2, not only TMP1 is generally increase with the running time but VMD1 is generally decrease with the running time, but also TMP1's up-down distribution is scattering broadly along with time but VMD1's up-down distribution is scattering narrowly along with time.

The second dimensionality reduction and statistical calculation

From previous research articles, permeability declined evaluation is based on daily data, which brings three problems due to this daily time base. The first critical issue is that no every daily data can be used in the assessment of T_{life} , but only few data of the days before and after the offline chemical cleaning can be utilized for calculating the T_{life} . Other than those few daily data used, 99% of daily data is abandoned and wasted. If only a few points, less than 1% has been used in the assessment, then the result is unconvincing. The second problem is that the daily data will face seasonal temperature and rainfall difference. It is well known that high temperature in summer season will benefit the permeate, and big rainfall can significantly reduced the effluent concentration and lead to increase the permeate. So the daily permeability data needs the temperature adjustment in order to compare with each other. But if an annual average permeability data is used, those seasonal temperature and rainfall could not be the problem anymore. There will not be necessary to do the adjustment.

The third issue is related to economic assessment. Not matter using net present value in bases for comparison of alternatives, or using depreciation in benefit-cost analysis, the most common time period is year. Therefore, daily data reduces into group data is not enough yet, group data must be reduced further into annual data. It is clear that the group units of each membrane tank have a specific time relationship with the

number of operating years. As the data in Table 1 show that there are 98 VMD groups in the 1# membrane tank. The running time represented by the 98 VMD groups is 9.644 years, and the $98/9.644=10.16$ groups are equal to 1 year. While for the 2# membrane tank the $109/9.644=11.30$ groups are equal to 1 year. While for the 3# membrane tank, the $106/9.644=10.99$ groups are equal to 1 year. The specific time relationship between the number of groups to one operating year is defined as the "ratio". The ratio of VMD1 for three membrane tanks is listed in Table 1. The second dimensionality reduction is conducted by year as "annual units". The TMP data can be treated by following the second dimensionality reduction method as VMD data. For 1# membrane tank 104TMP groups is 9.644 years, and the $104/9.644=10.78$ groups are equal to 1 year. While for the 2# membrane tank the $114/9.644=11.82$ groups are equal to 1 year. While for the 3# membrane tank, the $112/9.644=11.61$ groups are equal to 1 year. The ratio of TMP1 for three membrane tanks is listed in Table 2. There are two kinds of calculation method related to VMD2: cumulative VMD2 and regular VMD2.

Cumulative VMD2

The decrease of the membrane permeability has very close relationship with cumulative water production, which means that the membrane present performance is closely depended on its previous performance. The cumulative VMD2 is mathematically designed to reveal this cumulative relation.

$$Cum.CMD2 = \frac{\sum_{i=1}^n x_i}{n} \tag{5}$$

Where x_i is the the i^{th} VMD1, and there are n groups VMD1 in the cumulative period. The cum.VMD2 value and the number of groups for the different operating years of the 1# membrane tank are listed in Table 3.

Table 3. Cum.VMD2 value of the 1# membrane tank

Year	Cum.VMD2	n/#	Year	Cum.VMD2	n/#
1	19.071	10	6	15.573	61
2	17.279	20	7	15.421	72
3	16.278	30	8	15.056	82
4	16.058	41	9	14.574	92
5	15.731	51	9.644	14.240	98

The relationship between the cum.VMD2 and the whole operation process can be obtained from the data in Table 3, as shown in Figure 5.

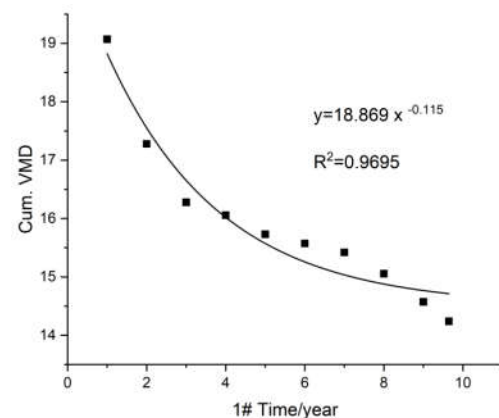

Figure 5. cum.VMD2vs time of 1# membrane tank

From the correlation between cum.VMD2 vs time, there are three results can be obtained. The first, the R square value is 0.9695, which proves that the present VMD2 is highly related with previous VMD2. Therefore, the MBR operation in whole 9.644 years is normal and smooth without any accidents. There are two dominant membrane failure modes: membrane permeability declined with running time and membrane integrity loss, such as membrane seal or connection failure, which can cause some catastrophic and unexpected problems. From very high R square value, it is reasonable to conclude that, for near 10 years practical operation, the membranes integrity loss does not present. Second, the correlation equation between cum.VMD2 and time mathematically is a power equation, so it needs at least three annual operation data in order to be regressed. In other words, only after three years' operation, the later performance can be predicted. The third, the most important, result is a negative value powder -0.115. The negative powder means cum.VMD2 is decreased along with time. Therefore, it is reasonable to focus the permeability decline phenomena of A²/O-MBR membrane RWTP during near 10 years operation.

Regular VMD2

The regular VMD2 is calculated based on:

$$VMD2 = \frac{\sum_{i=1}^j x_i}{j-i} \tag{6}$$

Where x_i is the the ith VMD1, and there are i to j groups VMD1 in the calculation. The regular VMD2 values of the 1[#] membrane tank are listed in Table 4.

Table 4. VMD2 of the 1[#] membrane tank

Year	VMD2	i to j /#	Year	VMD2	i to j /#
1	19.071	1-10	6	14.781	52-61
2	15.486	11-20	7	14.513	62-71
3	14.276	21-30	8	12.501	72-81
4	15.398	31-40	9	10.712	82-91
5	14.422	41-51	9.644	9.944	92-98

The difference between VMD2 and cum.VMD2 is that VMD2 only counting present operation without relating to previous operation. According to the data in Table 4, the VMD2 of the 1[#] membrane tank vs time is presented in Figure 6.

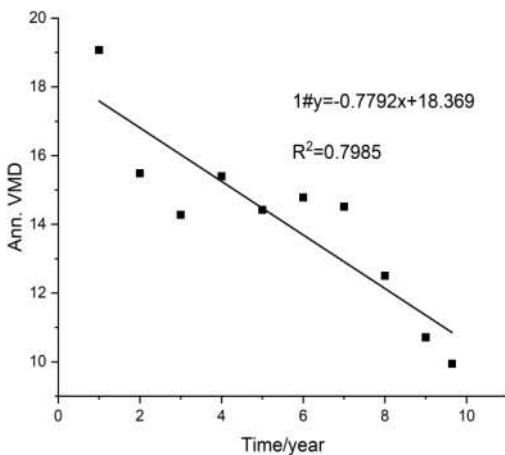

Figure 6. VMD2 vs time of 1# membrane tank

Clearly, the correlation between VMD2 and time is a linear relationship, can be presented mathematically with gradient intercept form

$$y = ax + b \tag{7}$$

Where a is the slop and b is the intercept. Similarly, the VMD2 vs time of other two membrane tanks is present in Figure 7.

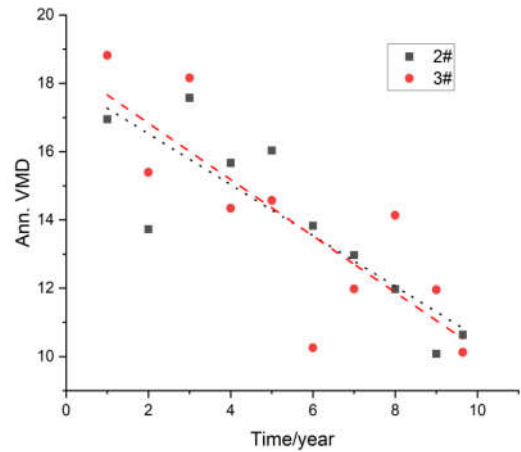

Figure 7. 2# and 3# membrane tanks' VMD2 vs time

Instead of treating each individual tank VMD2 separately, three tanks' VMD2 can be treated as three in one together, as shown in Figure 8.

Three membrane tanks and three in one VMD2 vs time equation parameters are listed in Table 5.

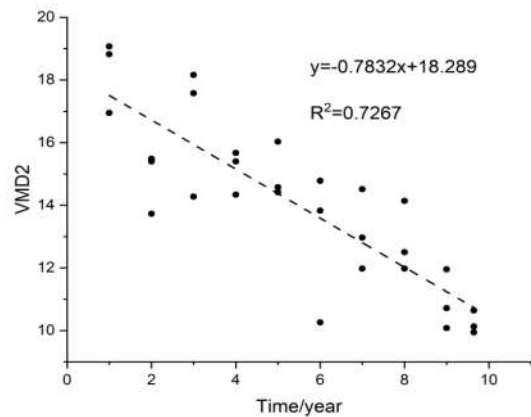

Figure 8. Three in one tank's VMD2 vs time

Table 5. The parameters of membrane tanks and three in one VMD2 vs time

Membrane tank	a	b	R ²
1#	-0.7792	18.369	0.7985
2#	-0.7446	18.014	0.7304
3#	-0.8256	18.486	0.6746
Three in one	-0.7832	18.289	0.7267

The characteristic in Table 5 is the negative slops, which is the incontestable evidence regarding the MBR membrane VMD2 attenuation. Based on three in one data, the VMD will decrease about 0.78 cubic meter permeate volume per day per 1000 meter square membrane area per kPa TMP annually.

Regular TMP2

The regular TMP2 is calculated based on:

$$TMP2 = \frac{\sum_i^j x_i}{j-i} \tag{8}$$

Where x_i is the i^{th} TMP1, and there are i to j groups TMP1 in the calculation. The regular TMP2 values of the 1[#] membrane tank are listed in Table 6.

Table 6. TMP2 values of the 1[#] membrane tank

Year	TMP2	i to j /#	Year	TMP2	i to j /#
1	16.817	1-11	6	25.685	55-65
2	22.635	12-22	7	24.908	66-76
3	24.189	23-33	8	26.633	77-87
4	22.496	34-44	9	26.415	88-98
5	21.382	45-54	9.644	26.188	99-104

The relationship between the TMP2 vs time of 1[#] membrane tank is presented in the Figure 9.

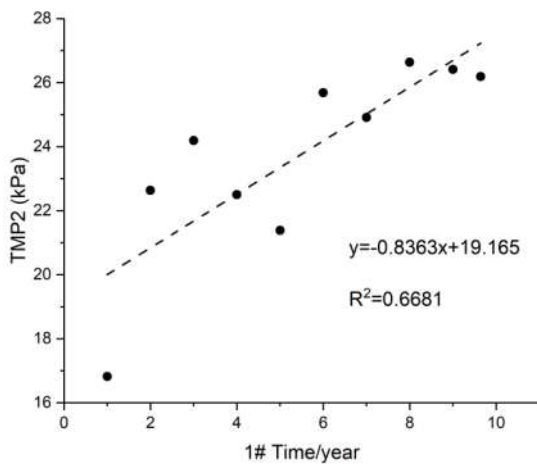

Figure 9. TMP2 vs time of 1[#] membrane tank

Similarly, the TMP2 vs time of other two membrane tanks is present in Figure 10.

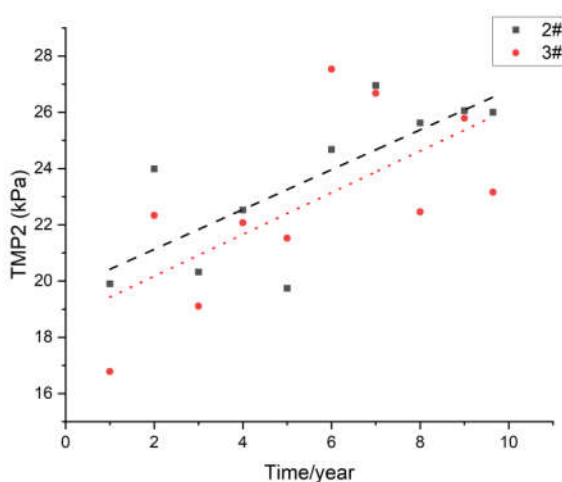

Figure 10. 2[#] and 3[#] membrane tank's TMP2 vs time

Instead of treating each individual tank TMP2 separately, three tanks' TMP2 can be treated as three in one together, as shown in Figure 11.

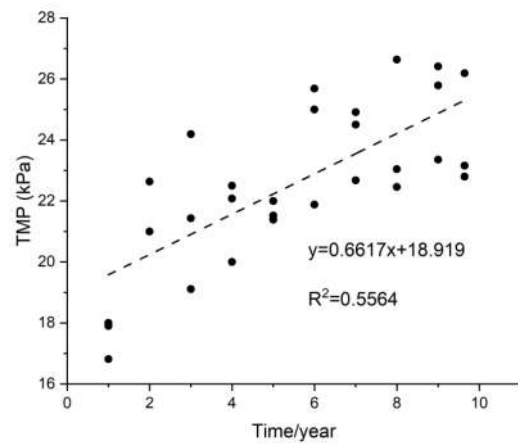

Figure 11. Three in one membrane tank's TMP2 vs time

All three membrane tank's TMP2 vs time equation parameters are listed in Table 7.

Table 7. The parameters of membrane tanks and three in one TMP2 vs time

Membrane tank	a	b	R ²
1#	0.8363	19.165	0.6681
2#	0.4766	19.005	0.7323
3#	0.6723	18.587	0.6405
Three in one	0.6617	18.919	0.5564

The characteristic in Table 7 is the positive slopes, which is the incontestable evidence regarding the MBR membrane TMP2 build-up. Based on three in one data, the TMP will increase about 0.66 kPa annually. It will be anticipated that if TMP was increased, then the energy usage would be increased, therefore, the operation cost would be increased eventually.

Production capacity decline

For this A²/O-MBR RWTP, Xi' an Siyuan University not only is the investor and manager, but also is the operator and user. Under a constant flux mode, and defines VMD to quantitatively monitoring the change of reclaimed water production rate, there are still a lot of technical and economic decisions must be made along with RWTP long-term operation. Typically, as membranes age, its irreversible fouling aggravated. Three phenomena can be observed simultaneously: the industrial permeability quantitatively declined; the trans-membrane pressure quantitatively increased, and the frequency of cleaning events qualitatively increases. From a practical point of view, the answers, which decision makers most want to know, are:

What is the present production capacity of the RWTP?

How does the present production capacity compare to designed production capacity for our RWTP?

If the membrane replacement is a planned campaign, which membrane tank should be replaced first?

How to arrange the replacement in the period of certain time based on our RWTP membrane tanks configuration?

Based on the specific value VMD2 and TMP2 of each membrane tank, the present production capacity (PPC, m³/day) for each membrane tank can be calculated through:

$$PPC \frac{m^3}{day} = VMD2 \times TMP2 \times 1.8 \tag{9}$$

The VMD2 of each individual membrane tank has been listed in Table 6, and the TMP2 of each individual membrane tank has been listed in Table 7. The calculated PPC values of three membrane tanks are listed in Table 8.

Table 8. PPC values of three membrane tanks at different time

Year	Mem. tank	VMD2	TMP2	PPC	Total PPC
1	1#	18.09	20.00	651.28	1869.09
	2#	17.27	19.48	605.58	
	3#	17.66	19.26	612.23	
2	1#	17.31	20.84	649.28	1846.91
	2#	16.52	19.96	593.65	
	3#	16.83	19.93	603.98	
3	1#	16.53	21.67	644.94	1819.11
	2#	15.78	20.43	580.44	
	3#	16.01	20.60	593.73	
4	1#	15.75	22.51	638.25	1785.69
	2#	15.04	20.91	565.95	
	3#	15.18	21.28	581.49	
5	1#	14.97	23.35	629.22	1746.65
	2#	14.29	21.39	550.18	
	3#	14.36	21.95	567.25	
6	1#	14.19	24.18	617.84	1701.98
	2#	13.55	21.86	533.14	
	3#	13.53	22.62	551.00	
7	1#	13.41	25.02	604.12	1651.70
	2#	12.80	22.34	514.81	
	3#	12.71	23.29	532.77	
8	1#	12.64	25.86	588.05	1595.79
	2#	12.06	22.82	495.21	
	3#	11.88	23.97	512.53	
9	1#	11.86	26.69	569.63	1534.26
	2#	11.31	23.29	474.34	
	3#	11.06	24.64	490.29	
9.644	1#	11.35	27.23	556.53	1491.66
	2#	10.83	23.60	460.22	
	3#	10.52	25.07	474.91	

Based on data in Table 8, the total PPC at different time is plotted in Figure 12.

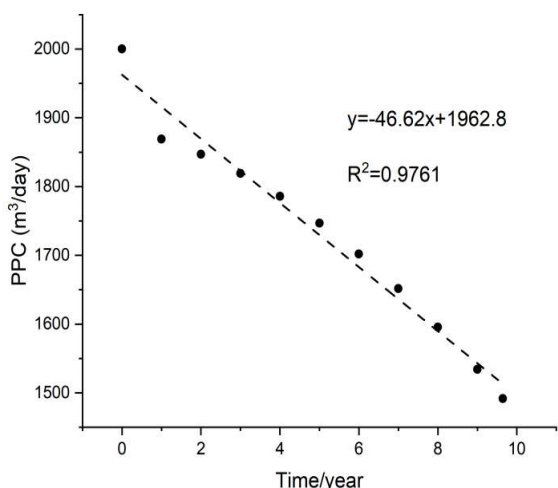

Figure 12. The total PPC vs time

The production capacity will annually decrease 47 cubic meter per day. After nearly 10 years operation, present production capacity is about 1490 cubic meter per day for RWTP. When to make decision of which membrane tank should be replaced first, it is necessary to calculate each membrane tank's VMD2, TMP2, and PPC.

Instead of calculating the VMD2 and TMP2 of three membrane tanks separately, there is three in one calculation of VMD2 and TMP2. In the three in one calculation, the 1.8 in Equation 9 will be replaced by 5.4. The all in one PPC vs time is plotted in Figure 13.

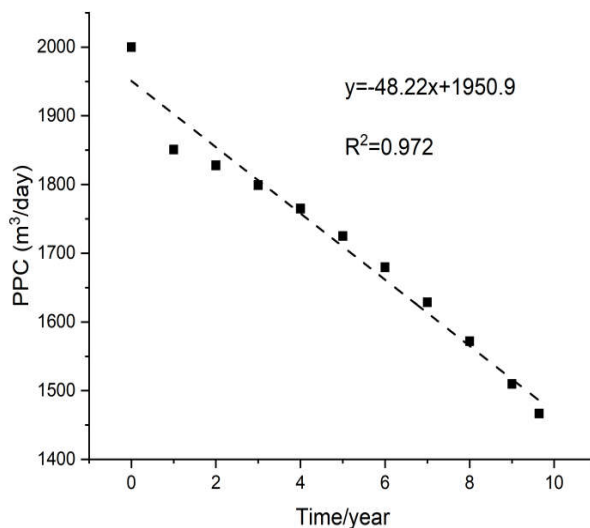

Figure 13. The all in one PPC vs time

Based on the all in one PPC calculation, the production capacity will annually decrease 48 cubic meter per day. After nearly 10 years operation, present production capacity is about 1467 cubic meter per day for RWTP.

Since the designed production capacity for three membrane tanks every day is 2000m³, the daily designed production capacity of every membrane tank should be 666.7 m³. The present production capacity to designed production capacity ratio(PDR, %) are calculated as:

$$PDR / \% = \frac{PPC}{DPC} \times 100\% \tag{10}$$

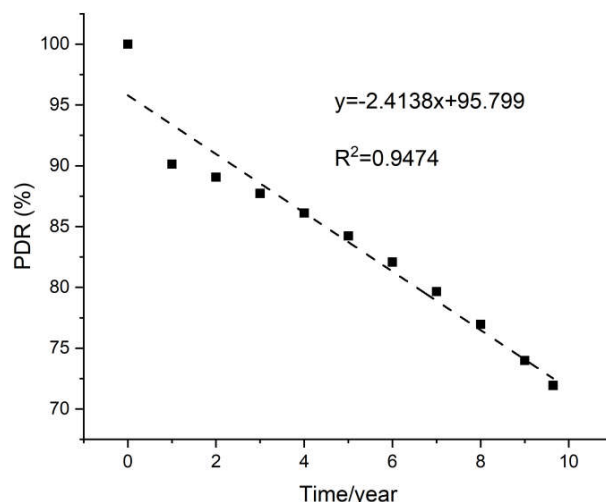

Figure 14. The PDR calculating based on three individual membrane tanks vs time

The production capacity will annually decrease 2.41 percent from the original designed capacity.

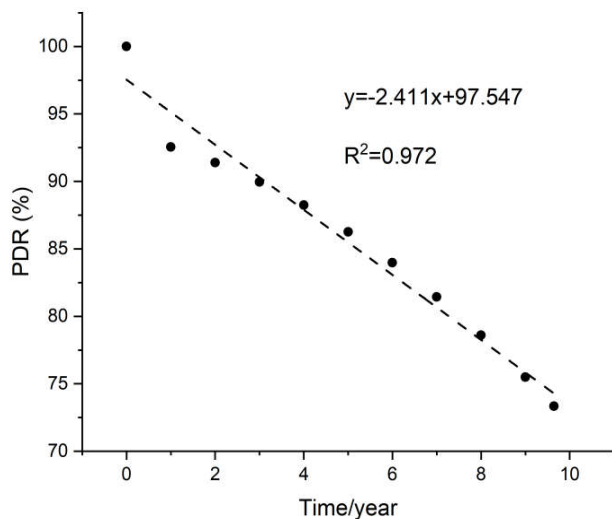

Figure 15. The PDR calculating based three in one vs time

Reasons of permeability attenuation

In previous discussion, the VMD is a fraction with daily permeate volume as the numerator and TMP as the denominator, therefore, reducing the numerator, or rising denominator, or reducing the numerator and rising denominator simultaneously should be three ways to decrease VMD. Based on our practical operation, the VMD is decreased about 4.28% annually (refer to the section 3.6), the TMP is increased about 3.50% annually (refer to the section 3.7), and production capacity is decreased 2.47% annually (refer to the section 3.8).

Conclusion

All 3520 days' operational data have been used to study an evaluation method of MBR membrane replacement. The industrial permeability, VMD, has been defined as the cubic meters per day per 1000 meter square membrane area per kPa trans-membrane pressure, TMP. The first and the second dimensionality reduction have been carried out to obtain the annual VMD2 from the daily VMD, as well as the annual TMP2 from the daily TMP. Typically, as membranes age, three phenomena can be observed simultaneously. The industrial permeability quantitatively declined, the VMD will decrease about 0.78 cubic meter permeate volume per day per 1000 meter square membrane area per kPa TMP annually; The trans-membrane pressure quantitatively increased, the TMP will increase about 0.66 kPa annually; The production capacity will annually decrease 47 cubic meter per day, and the production capacity will annually decrease 2.41 % from the original designed capacity. The frequency of cleaning events qualitatively increases. The membrane replacement is a technical and economic planned exercise. Replacement capital cost: new membrane procurement, operation cost: lower TMP, lower energy cost, less chemical cleaning, higher chemical cleaning efficiency, lower operation cost. Lower potential risks in operation. Continual running without membrane replacement: no new membrane purchasing cost, no capital cost. Higher TMP, higher energy cost, more chemical cleaning, lower chemical cleaning efficiency, higher operation cost. higher potential risks in operation. The decision of planned exercise is to calculate whether or not earlier membrane replacement can be counterbalanced by energy costs saving.

Abbreviation

BW, backwash; DPC, designed production capacity, m³/day; LMH, flux, liter per centimeter square per hour; MBR, membrane bio-reactor; PDR, present production capacity to designed production capacity ratio, %; PPC, present production capacity, m³/day; RWTP, reclaimed water treatment plant; T_{life} , membrane life time; TMP, trans-membrane pressure; TMP1, arithmetic mean of the first dimensionality reduction with 25 valid daily TMP as one group; TMP2, arithmetic mean of the second dimensionality reduction with annual TMP1; VMD, industrial permeability, cubic meters per 1000 meter square per day per kPa TMP; VMD1, arithmetic mean of the first dimensionality reduction with 25 valid daily VMD as one group; stdevVMD1, stand deviation of VMD1; VMD2, arithmetic mean of the second dimensionality reduction with annual VMD1; cumVMD2, cumulative VMD2.

REFERENCES

- Cote P.Z., Alam, J. Penny. Hollow fiber membrane life in membrane bioreactors (MBR). *Desalination*, 2012, 88(13): 145-151.
- Fan X. J., L. L. Jiang, X. H. Liu. Engineering design of integrated MBR process for municipal wastewater treatment. *China Water & Wastewater*, 2010, 26(10): 47-50 (in Chinese).
- Fenu A. , W. De Wilde, M. Gaertner, M. Weemaes, G. de Gueldre, B. Van De Steene. Elaborating the membrane life concept in a full scale hollow-fibers MBR[J]. *Journal of Membrane Science*. 421-422(2012): 349-354.
- Hou W. X., G. Y. Zhang, T. X. Zhong. The application example in municipal reclaimed water of enhanced nitrogen and phosphorus removal MBR process. *City and Town Water Supply*, 2011, 16(S1):152-155 (in Chinese).
- Jiang L. L., W. L. Zhang, T. Liang, B. Hu. Study on degradation characteristics of two anoxic A(2A)O-MBR wastewater treatment system. *Technology of Water Treatment*, 2013, 39(1): 93-96 (in Chinese).
- Li D., H. S. Zhang, B. Fu, B. L. Qin, J. Y. Hao. Analysis of water reuse in A2O / MBR-Take Xi'an Siyuan University as an example [J]. *Water supply and drainage*, 2017, 43 (S1): 163-166 (in Chinese).
- Li D., J. Y. Hao, Q. H. Ma, X. M. Zhang, B. Fu, B. L. Qin. Long-term operational data analysis of the MBR process [J]. *Water Purification Technology*, 2019, 38 (6): 92-96. (in Chinese).
- Li D., Q. H. Wang, B. Fu, B. L. Qin, X. M. Zhang, Q. H. Ma. Final accounts and operation cost analysis of the sewage treatment and reclaimed water reuse system of Xi'an Siyuan University [J]. *Water pollution and treatment*, 2022,10 (1): 26-34. <https://doi.org/10.12677/WPT.2022.101004> (in Chinese).
- Li D., X. M. Zhang, B. Fu, B. L. Qin, Q. H. Ma. Application of big data technology in sewage MBR membrane life prediction in universities' wastewater treatment [J]. *Progress in Applied Mathematics*, 2022,11 (1): 583-589. <https://doi.org/10.12677/aam.2022.111065> (in Chinese).
- Li D., X. M. Zhang, B. L. Qin, B. Fu, Q. H. Ma. Gas Float-A2/O-MBR Process on Campus Wastewater Treatment-Taking Xi'an Siyuan College as an Example. *Chemical Engineering and Technology*, 2022, 12(1), 32-39. <https://doi.org/10.12677/hjct.2022.121005> (in Chinese).

- Liu H. F., S. L. Yu, L. Gao, X. F. Song, Y. Q. Wu, M. Di. The separation performance change of ultra-filtration membrane in water treatment plant and membrane life-time prediction. *Water & Wastewater Engineering*, 2020, 46 (7) : 47-53 (in Chinese).
- Meng F., S.-R. Chae, A. Drews, M. Kraume, H.-S. Shin, F. Yang, Recent advances in membrane bioreactors (MBRs): membrane fouling and membrane material, *Water Res.* 43 (2009) 1489–1512.
- Verrecht B., T. Maere, I. Nopens, C. Brepols, S. Judd. The cost of a large-scale hollow fibre MBR. *Water Research*, 2010, 44(18): 5274–5283.
- Wang X. S., J. H. Gao, B. Ai, Q. Fu, J. Chang, Y. P. Gan. Evaluation of membrane life span in a full scale MBR Process for reclaimed water treatment plant[J], *Water Purification Technology*, 2014,33 (5): 24-27 (in Chinese).
- Xiao K., Y. Xu, S. Liang, T. Lei, J.Y. Sun, X.H. Wen, H.X. Zhang, C.S. Chen, X. Huang. Engineering application of membrane bioreactor for wastewater treatment in China: Current state and future prospect. *Front. Environ. Sci. Eng.* 2014, 8(6): 805-819.
- Xu Y., T. Lei, J. Y. Sun, J. L. Xia, T. Xue, K. C. Yu, J. Guan, Y. L. Chen, X. Huang. Life-time assessment of membrane in large-scale MBR plant for municipal wastewater treatment[J], *China Water & Wastewater*, 2015, 31 (5): 34-39 (in Chinese).
- Yang A. M., Y. P. Gan, J. Chang, B. Ai, Y. Z. Peng. Process introduction of MBR of Beijing Beixiaohe reclaimed water plant. *Membrane Science and Technology*, 2011, 31(4): 95–99 (in Chinese).
- Zhang X. M., J. Y. Hao, Q. H. Ma, D. Li. Comprehensive Analysis of 9-year Running Data of A2O-MBR in Xi'an Siyuan University. *Meteorological and Environmental Research*. 2020, 11(5):139-143.
- Zhang Y.Y., Y. M. Guo, B. Liu, F. Guo, Y. N. Zhang, Y. F. Zhang, Y. M. Chen. Application of 3AMBR in the fourth wastewater treatment plant of Kunming. *Chinese Journal of Environmental Engineering*, 2013, 7(9): 3409–3414 (in Chinese).
- Zhou S. H., B. Fu, D. Li, B. L. Qin, Q. H. Wang. Study on MBR Cleaning Process [J]. *Water pollution and treatment*, 2022,10 (1): 13-25. <https://doi.org/10.12677/WPT.2022.101003> (in Chinese).
